



3D X-RAY TOMOGRAPHY SYSTEMS



www.rx-solutions.com

Performance Made Easy

**INDUSTRIAL
COMPUTED TOMOGRAPHY
HIGH PERFORMANCE X-RAY SYSTEMS**

RX Solutions is 100% focused on X-ray imaging solutions. The aim at RX Solutions has always been to provide customers with the best X-ray and CT solutions, for inspecting and analyzing both external and internal features of parts.

RX Solutions designs, manufactures and supports one of the broadest range of high performance CT systems, from micro to nano scale analysis.

Innovative technology
to reveal hidden structures of your parts

Innovation is at the core of our mission, whether it is for quality control, examination of a component or solving design issues. With an important investment in R&D, our team of experts and engineers are committed to serving different industrial & academic sectors and working in close collaboration with our customers to ensure highest levels of performance.



An expert by your side

With a continuous improvement approach, we aim to increase our customers' industrial productivity & development without compromising quality, reliability & safety.

Customer proximity means we integrate in our offer: training, maintenance, support and all the services that optimize the performance of our equipment within its applications. By closely cooperating with our global distribution partners, we give you easy access to our high-grade expertise and support.



Team of experts



Worldwide distribution



ISO 9001 quality management



What's best with CT ?

X-Ray Computed Tomography
The most advanced technology for 3D Inspection

Virtual sample cut

X-ray CT allows to virtually cut the scanned sample in any orientation for high resolution visualization and analysis of thin slices at any depth

One single scan - multiple data

One scan allows multiple analyses to be performed: dimensional measurements, material characterization, defects analysis and inspections of inner structures in a non-destructive way

Inspect and reproduce any assembly

X-ray CT provides a detailed rendering of all the internal and external features. Point clouds representing the surfaces can be extracted allowing parts to be easily reproduced even when CAD models are no longer available

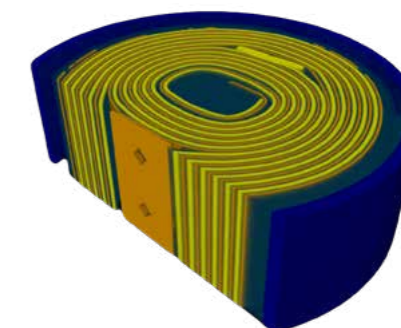

Computed Tomography at all stages *of product life cycle*

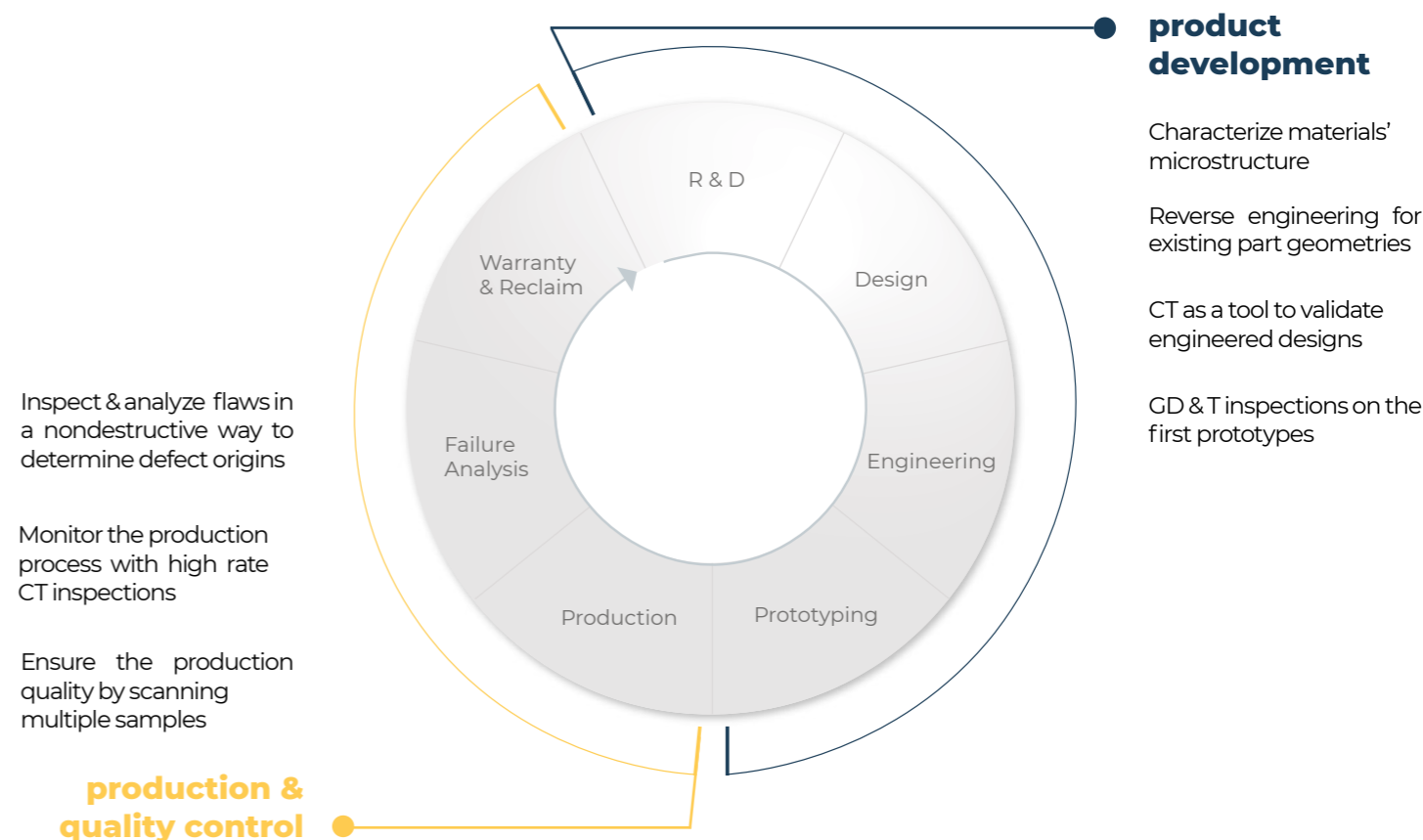

OUR EXPERTISE

REVEAL ALL DETAILS OF YOUR PARTS

Computed Tomography offers a significant advantage for various industries because of its ability to reveal hidden details of your parts. Getting a perfect insight of the invisible features of your parts allows you to capture, investigate, measure & analyze internal and external structures of your components in a nondestructive way.

RX Solutions offers complete and powerful X-ray CT systems with the finest level of detail: resolution down to sub-micron level, covering both industrial and academic applications.

CT systems portfolio covers a large scale of analysis, from Micro focus (4 μm) to Nano focus (0.4 μm) to satisfy a broad spectrum of applications.



High resolution

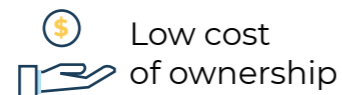

Low cost of ownership

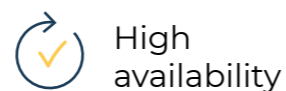

High availability



Artefacts corrections

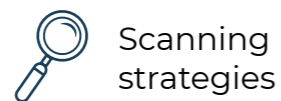

Scanning strategies



User friendly

Highly configurable CT systems

There is no need to compromise, RX Solutions has a solution for every application. The broad portfolio covers all sample sizes, and every application allowing multiple configurations with the most appropriate components:



Multi axis mechanics



X-ray tube configuration

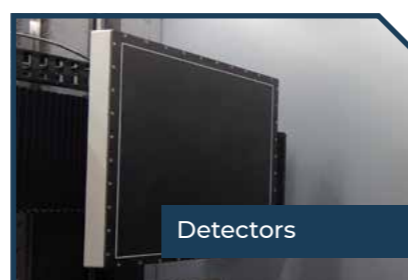

Detectors

Micro and Nano mechanics with high grade honeycomb optical breakeboards or granite base.

Variety of micro and nano focus tubes available. Dual-tube configuration available, to combine high power and high resolution.

Large choice of flat panels and high resolution cameras.

EasyTom S



Compact. Medium size samples. Maximized uptime.

EasyTom



Flexible. Micro & Nano focus. Medium size samples.

EasyTom XL



Powerful. Step-in cabinet. Large size samples.

UltraTom

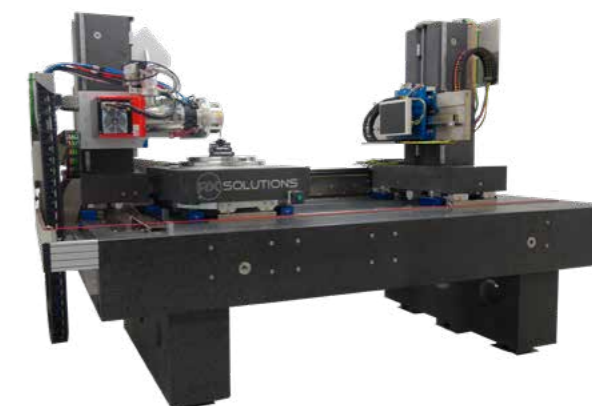

Lab CT system. Bunker. Multi tubes & detectors configurations.

KEY FEATURES // HIGHLIGHTS

- **Extremely High Resolution**
Outstanding CT resolution down to 0,4 μm
First class mechanics
- **Flexible solutions**
Wide range of applications
Easy to use & maintain
Small footprint & easy integration
- **Automatic Object Positioning**
High-grade manipulators
Up to 9-axes kinematics & live view
- **One scan, multiple inspections**
Material analysis
Geometry and Metrology
- **Lasting investment**
Upgradable CT solutions
Reliable and proven CT equipment
- **Powerful & advanced software**
Intuitive Acquisition & Reconstruction
Multiple scanning strategies

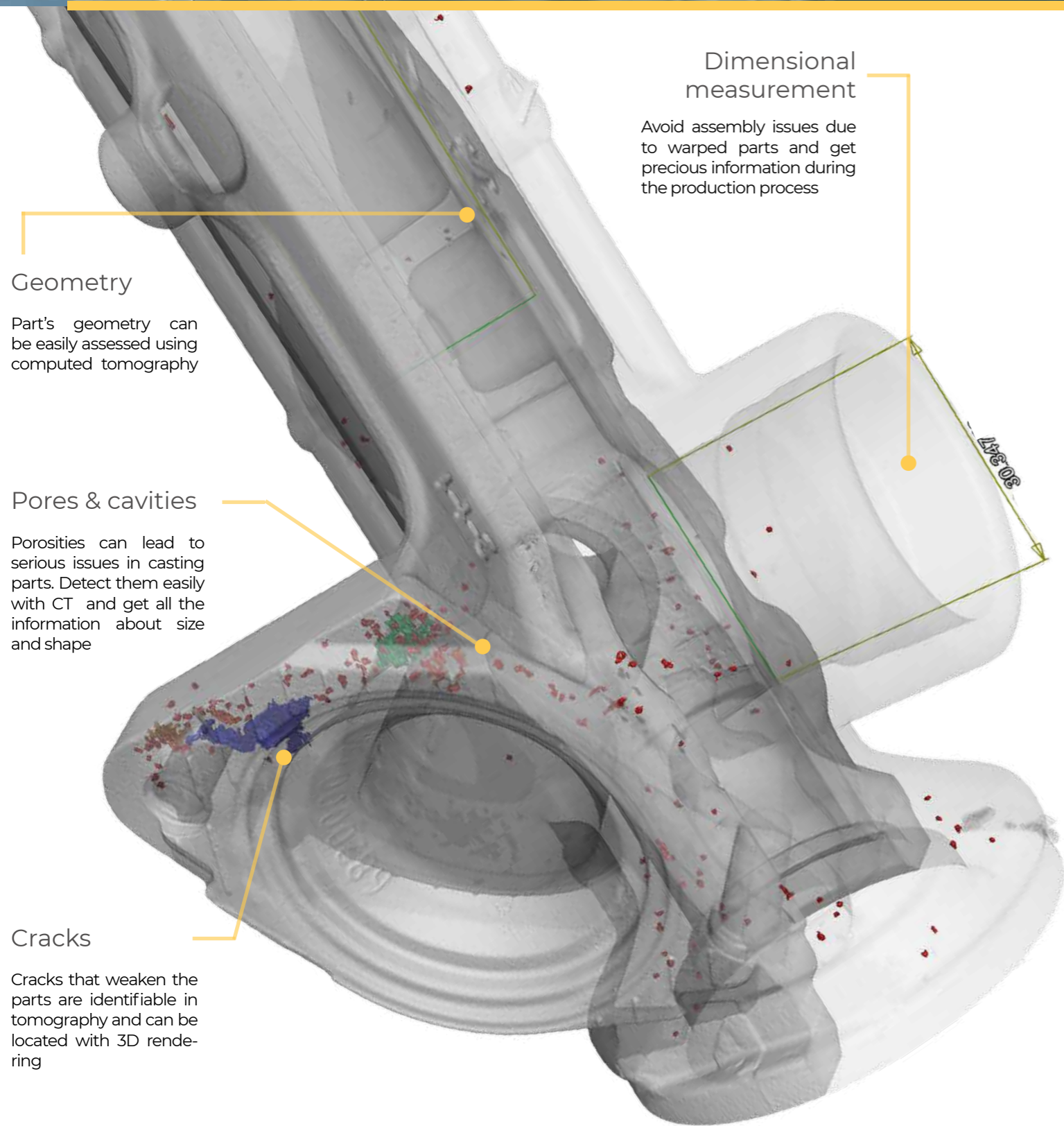

Geometry

Part's geometry can be easily assessed using computed tomography

Pores & cavities

Porosities can lead to serious issues in casting parts. Detect them easily with CT and get all the information about size and shape

Cracks

Cracks that weaken the parts are identifiable in tomography and can be located with 3D rendering

Dimensional measurement

Avoid assembly issues due to warped parts and get precious information during the production process

Material analysis

- Micro structure analysis
- Fiber Analysis
- Welding characterization
- Assembly inspection
- Failure analysis

Geometry & Metrology

- Wall - thickness analysis
- Comparison
- Reverse engineering

NANO technology

Explore beyond the limits
Ultimate CT performance in your lab

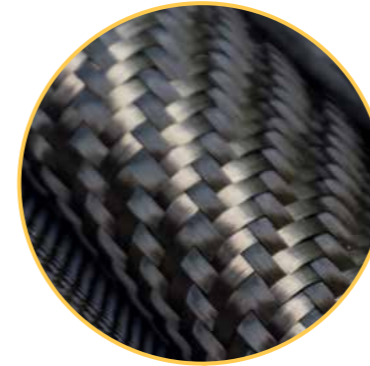

Nano-CT is a high resolution technology for 3D imaging at sub-micron resolution. The technical concept is based on a further development of micro-CT technology. By improving the spatial resolution, structures at a cellular level become visible.



Nano-CT on a composite sample as follows :

- resolution of 0.7 μm
- sub volume extraction also called ROI (Region of Interest)

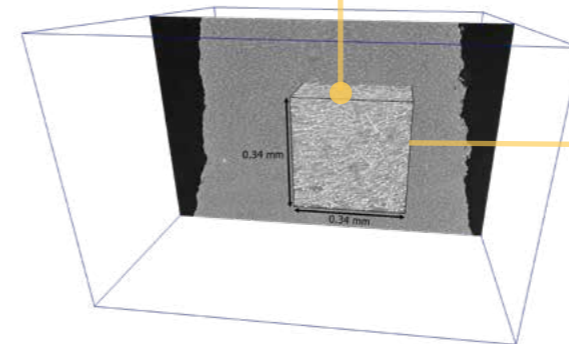

Fibers scale extraction

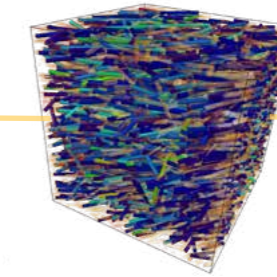

Fiber length color coding

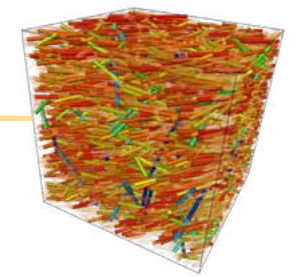

Fiber orientation color coding

Our focus industries



Additive manufacturing



Aerospace



Automotive



Arts & jewels



Composite



Defence

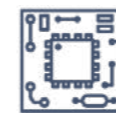

Electronics



Medical & Dental



Injection molding



Oil & gas



Plastics



Research & Science

High performance & compact CT system

The most compact equipment for small to medium sized parts

RX Solutions EasyTom S is a compact and powerful CT System designed to address the most challenging 3D applications ranging from material research to industrial applications in R&D, quality assurance and production. Ideal for metrology.

With this new compact equipment, it is now possible to visualize, measure and analyze with high resolution large components or assemblies, up to 180 mm in diameter and 400 mm in height.



No compromise, a solution for every application

EasyTom S can be configured and upgraded with numerous optional features to perfectly meet your specific applications.

X-ray tubes

High power microfocus X-ray generators: 110 to 150 kV.

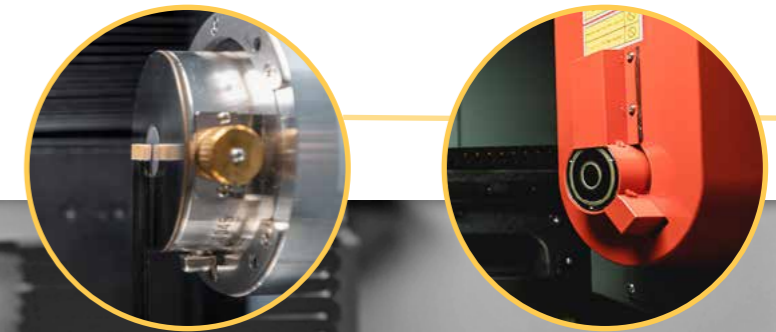

Long lasting investment

Scalable CT solutions. Reliable and easy to maintain.

High performance

Outstanding resolution down to 2 µm. First class mechanics: 4 high precision granite mechanical axes.

Flexible solution

Large inspection volume (ø 180 x H 400 mm). Easy integration with compact footprint: H.1870mm – W.1430mm – D.890mm.

Automation meets accuracy



Filter changer

Automatic filter selection to perform batch CT scans of multiple samples of diverse materials.



Sample loader

Scan multiple parts without operator intervention needed. Automatic scan overnight for 24/7 operation mode.



High resolution camera

Optional high resolution camera for scans on large warped objects.

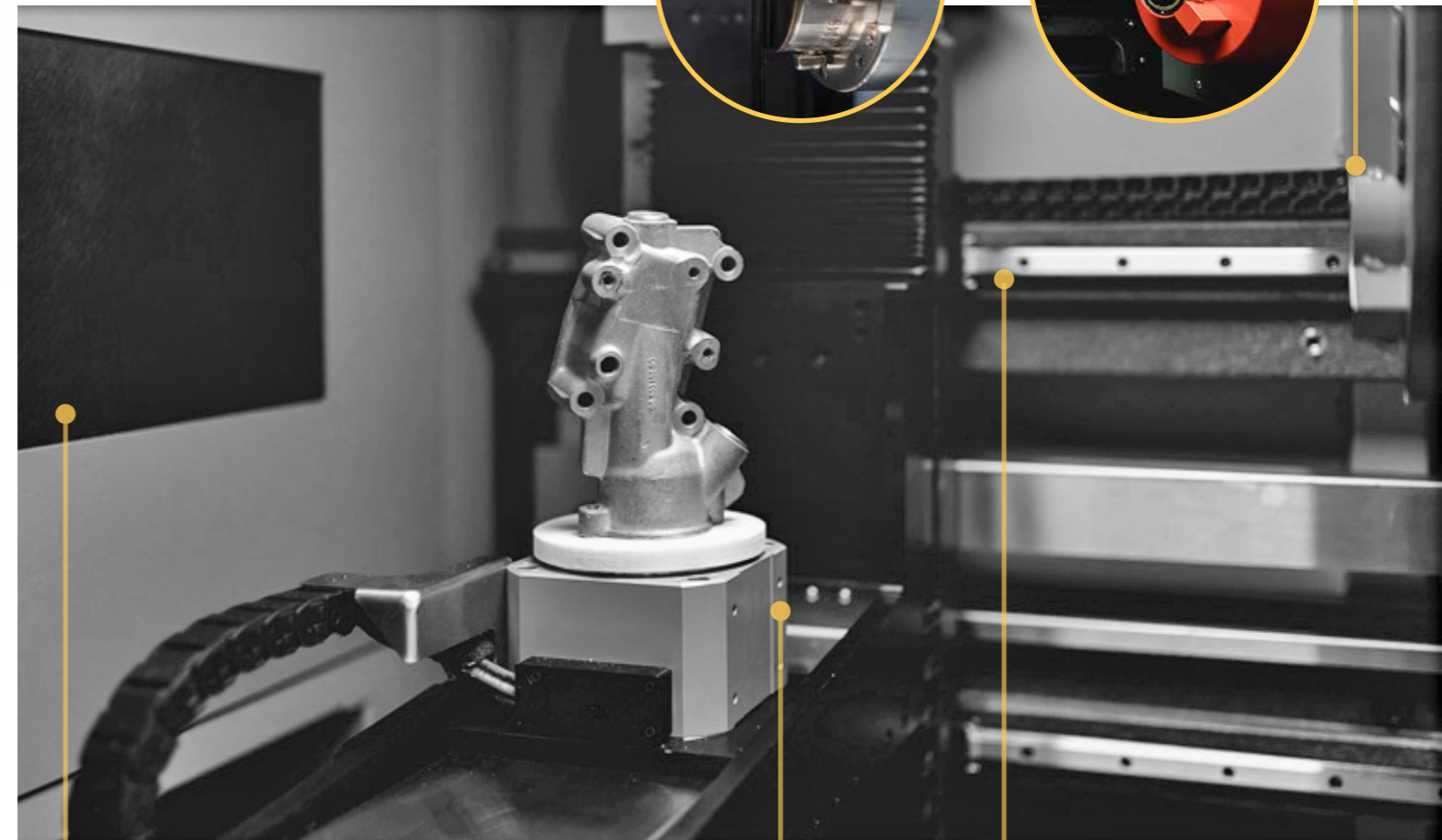

X-ray detector

High-grade detectors with multiple choice: Flat panel and high resolution camera.

Rotation stage

High-precision rotation stage.

Multi axes mechanics

First-class mechanic with granite axes for long-term stability, 4 axes manipulator.

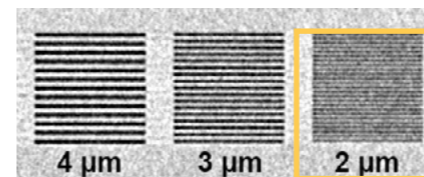

QRM microchart 3D resolution of 2 µm

Compact and powerful equipment

High grade resolution gives sharp details as well as the balanced contrast and brightness.

Inspection volume : Ø 180 mm & H 400 mm

High resolution micro & nano CT system

The most powerful equipment for small to medium sized parts

Designed to address the most challenging 3D applications, from material research to industrial applications in R&D, quality assurance and production, EasyTom delivers images of highest quality.

With an ultimate resolution down to 0.4 μm and multiple tubes & detectors choices, EasyTom has a large scanning volume up to 320 mm in diameter and 530 mm in height.



High-grade components

First-class mechanics: granite axes for long term stability. High grade X-ray tubes and detectors.

High resolution

Outstanding resolution down to 0.4 μm . Tomography at a sub-micron scale or both micron and sub-micron: single or dual tube configuration.

Flexible solution

Large scanning volume 320 x 530 mm. Easy integration : medium size system. Ideal for In situ applications.

Flexible and powerful



Large leaded windows

Large leaded windows on the front side allow a direct view during the setup and scan of the sample.

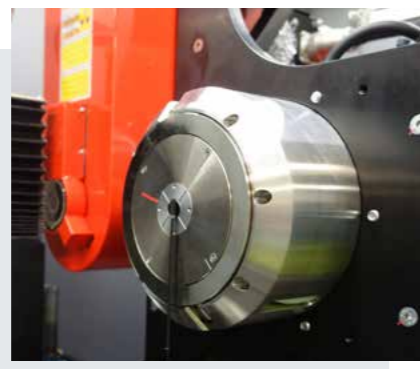

Dual tube configuration

No compromise: combine high resolution and high power micro and nano X-ray computed tomography.

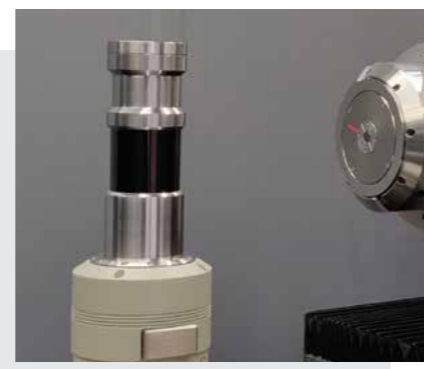

In Situ Design

Large internal volume design for: tensile, compression, bending & temperature testing devices.

X-ray detectors

Multiple choices of high resolution flat panels and cameras can easily be swapped to meet and match the scan conditions and required performance.

X-ray tubes

Optional dual tube configuration. Nano & micro-focus tube up to 230 kV guarantee excellent penetration and fast scans.

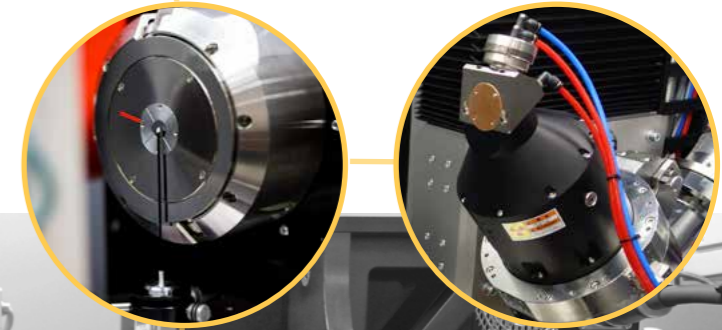

NANO

MICRO

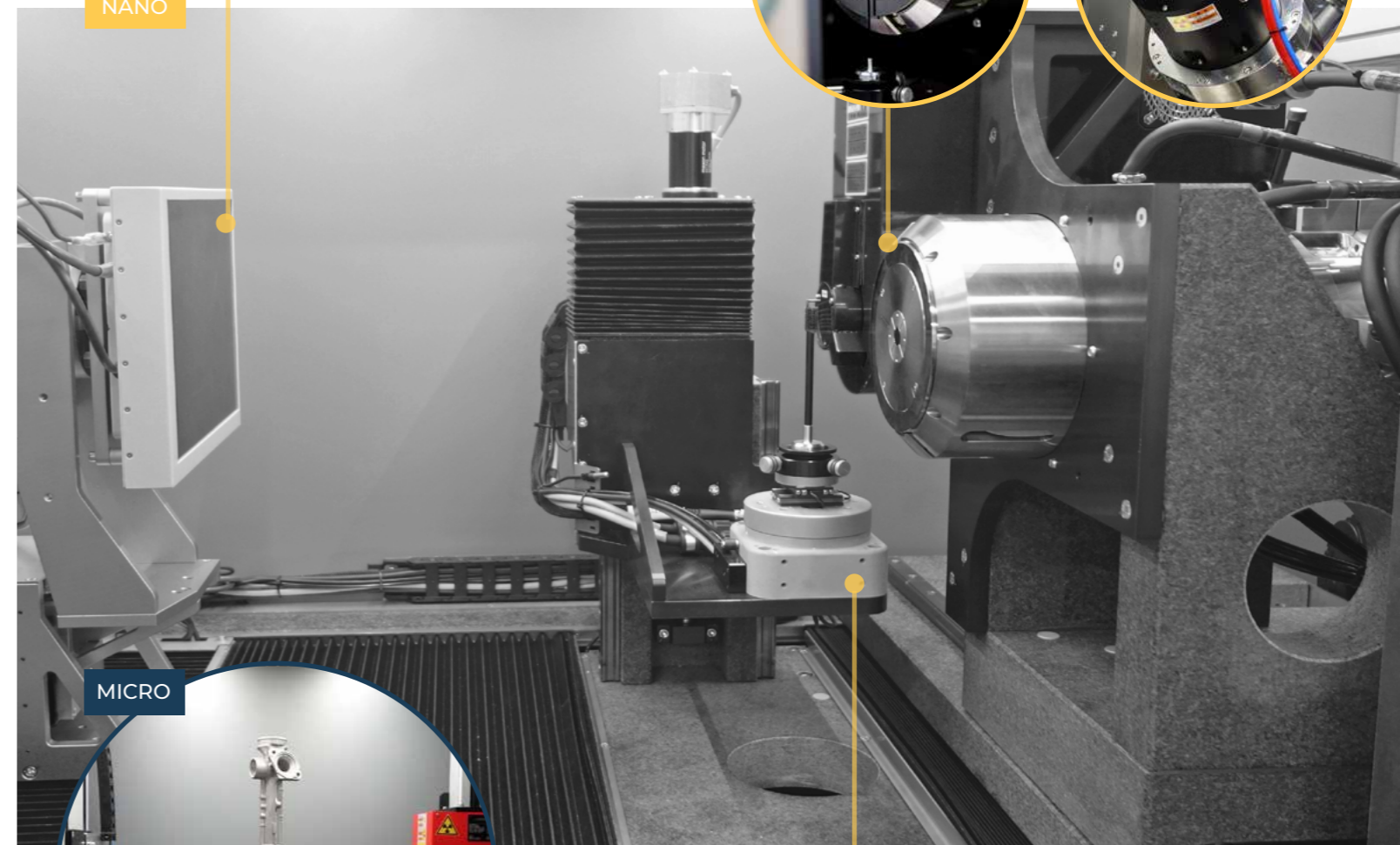

Manipulator

High-grade granite axes for long term stability with variable distance to achieve the best resolution. Up to 9 axes. Air bearing rotation stage with optional motorized centering stage.

Highly configurable : Micro or Nano Mechanics

Micro & Nano Mechanics with high grade honeycomb optical table or granite base.

Inspection volume : \varnothing 320 mm & H 530 mm

High resolution micro & nano CT system

The largest step-in cabinet CT equipment

The EasyTom XL CT scanner is the largest system available in cabinet configuration. The large scanning volume allows for unparalleled inspection of very large objects and such EasyTom XL is the only step-in cabinet allowing a combination of high power and high resolution X-ray sources: nano focus 160 kV & micro focus 230 kV.

The ability to house an X-ray tube of 230 kV means thicker and denser samples can also be inspected, with an ultimate resolution down to 0.4 μm .



Modular design

Highly modular with combination of high power and high resolution. X-Ray sources : up to 2 X-ray tubes including nano 160 kV & micro 230 kV.

High resolution

Outstanding resolution down to 0.4 μm . Tomography at a sub-micron scale or both micron and sub-micron: single or dual tube configurations.

Flexible solution

Large inspection volume with multiple axes (\varnothing 600 mm x H 720 mm). Ideal for In situ applications.

Multifunctional and freely configurable



Large scanning volume

The large scanning volume of the system offers unparalleled inspection of sizable objects.



In situ experiments

Large internal volume and pass through ports, ideal to host and control stages used for In situ scans.

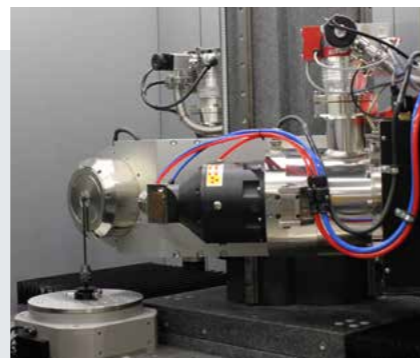

High power & resolution

Both fast and high resolution scans can be executed in one equipment system with an instantaneous switch between micro & nano.

X-ray detector

Multiple choices of high resolution flat panels and camera to get the best results for any sample coupled with a high-precision detector holder.

X-ray tubes

Optional dual tube configuration. Nano & micro-focus tube up to 230 kV guarantee excellent penetration

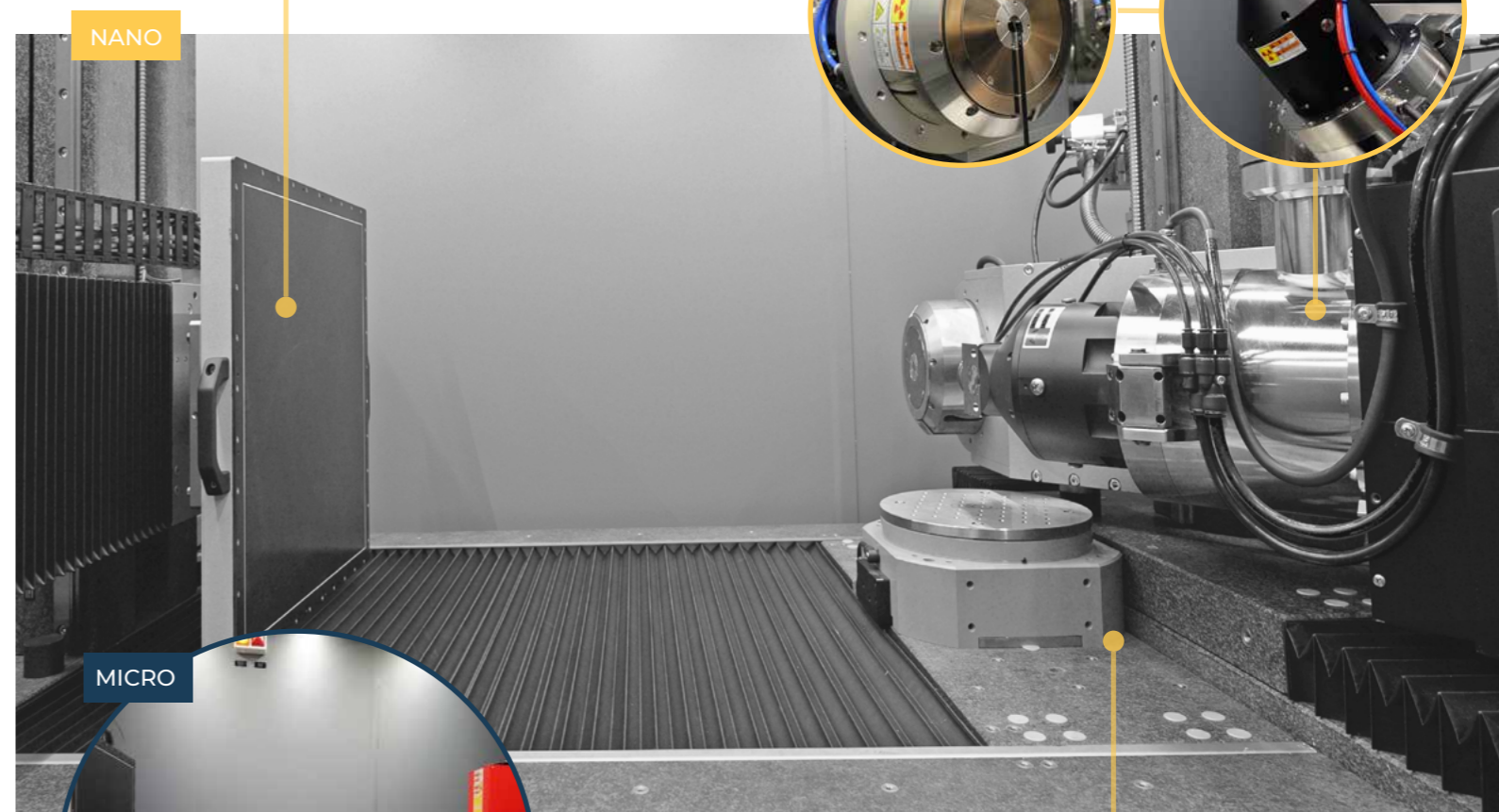
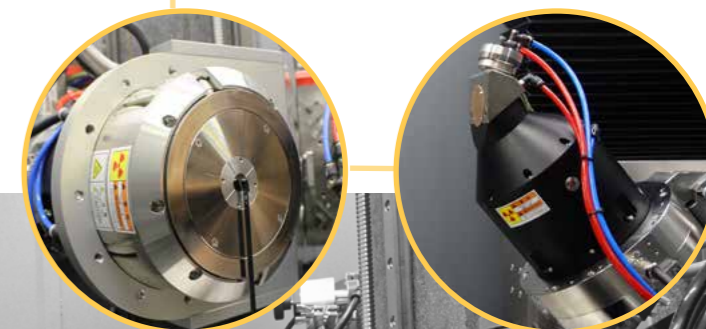

NANO

MICRO

Manipulator

High-grade granite axes for long term stability with variable distance to achieve the best resolution. Air bearing rotation stage with optional motorized centering stage.

Highly configurable : Micro or Nano Mechanics

Micro & Nano Mechanics with high grade honeycomb optical table or granite base.

Inspection volume : \varnothing 600 mm & H 720 mm

High flexibility & powerful CT system

The ultimate flexible system hosted in a bunker

An open and flexible system, hosted in a large bunker, ideal for academic research and for industrial R&D applications. Its greatest asset, among many others, is the fact that it can be tailored to each test requirement. The space all-around the system enables easy access even to setup the most comprehensive in-situ CT experiments.

As a very powerful system, it has been designed to perfectly address the most challenging 3D applications ranging from material research to industrial applications in R&D, quality assurance and production.

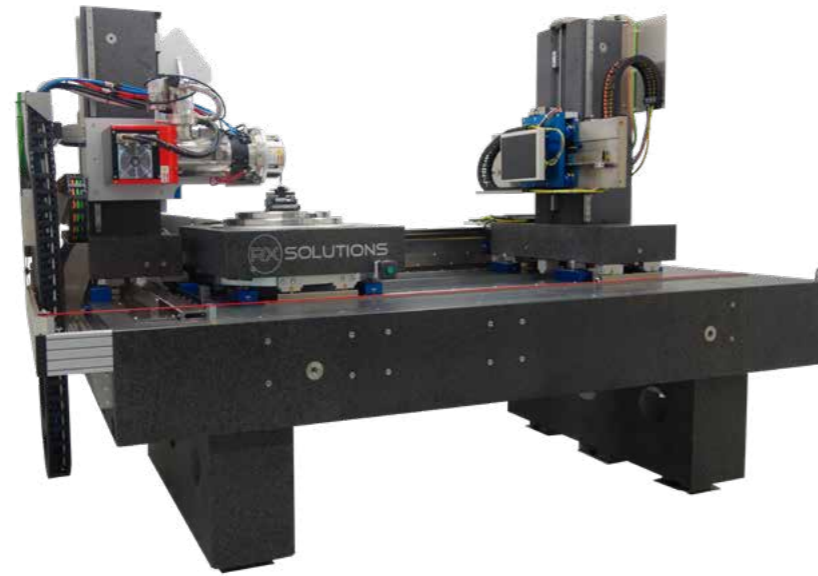

Open design

Lab set-up customized for your applications: configurable detectors, high speed cameras.
Highly modular: high power & high resolution X-Ray sources with up to 3 X-ray tubes including nano-focus 160 kV & micro-focus 300 kV.

High resolution

Outstanding resolution down to 0.4 μm .
First-class mechanics: finest stability, high precision granite table, air bearing axes guarantee stiffness, high precision linear encoders.

Flexible solution

Large inspection volume with 9 mechanical axes (\varnothing 520 mm x 650 mm). Scalable CT system.
Large space around the system for easy access to the setup.

Freely configurable Lab CT system

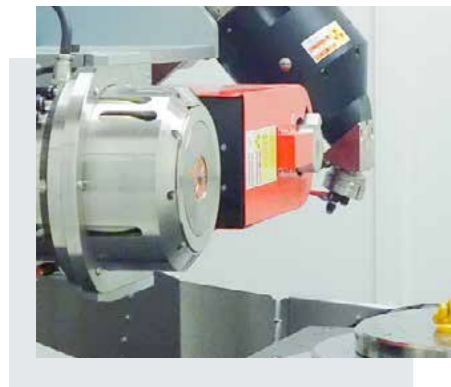

Micro & Nano focus tubes

High-resolution configurations of tubes up to a maximum of 300 kV guarantee a very high resolution and short scanning times



Lab solution design for In situ

Lab CT system that can be enhanced with In situ testing for dimensional measurements and material testing under specific test conditions



Scalable CT system

UltraTom can be upgraded at any moment with a large choice of tubes, flat panels and cameras

X-ray tubes

High-grade X-ray sources : up to 3 X-ray tubes including nano-focus 160 kV and micro-focus 300 kV, to ensure excellent material penetration.

X-ray detectors

Multiple choices of high resolution flat panels and cameras to get the best results for any sample coupled with a high-precision detector holder.

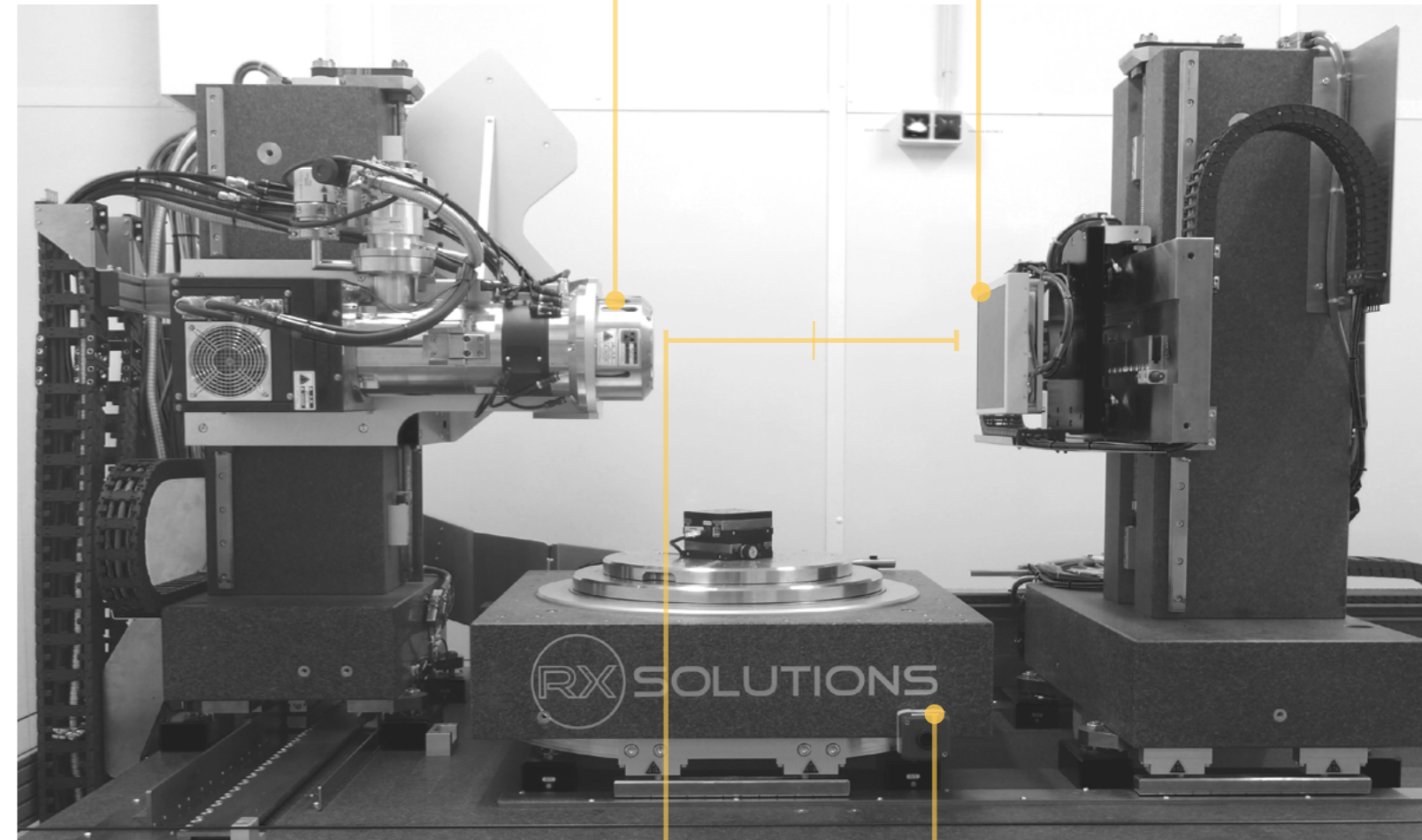

Tube to Detector distance

The distance between the tube and detector determines the available magnification range. With its large distance up to 1640 mm, Ultratom provides the magnification required to achieve the highest resolution for any sample size and scan configuration.

Precision axes

First-class multi axes mechanic with high-grade granite axes for long term stability. Heavy load. Motorized centering stage.

Inspection volume : \varnothing 520 mm & H 650 mm

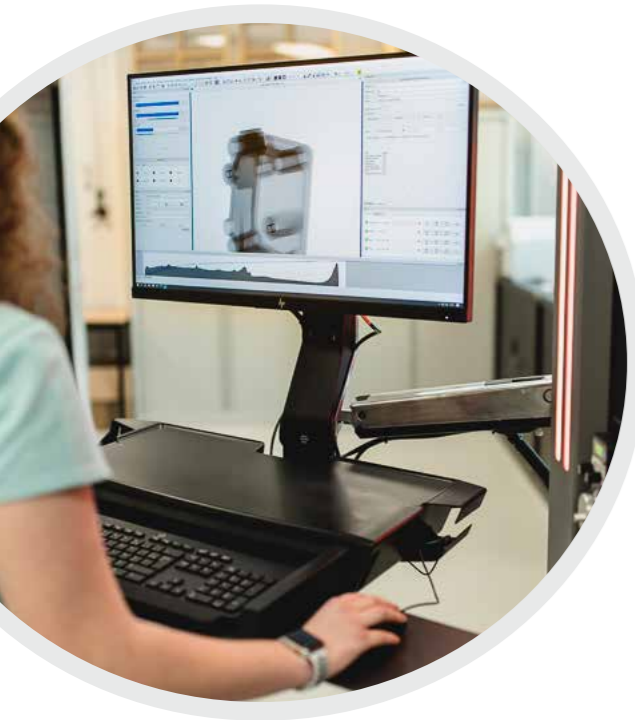

Powerful, advanced & intuitive software

Everything is combined in a single X-ray software from the setup to the CT scan's 3D rendering

X-Act software integrates a complete interface to accurately inspect your samples.

This is an acquisition and reconstruction software that, as an advanced solution, integrates a large number of functionalities enabling optimized results for any sample.

Multiple Scanning Strategies & Great Flexibility

X-Act is a powerful software with an easy and intuitive user interface. Delivered with an incredible number of functionalities, X-Act enables you to set the perfect parameters for the scanning process, for any kind of sample.

X-Act allows multiple scanning strategies, from conventional CT scan mode to multiple advanced acquisitions capabilities, such as helical, stack, shift, laminography, limited angles, Region of interest zooming, Dynamic 4D CT...



Radiography

Live inspection

Radiography is quick and easy with X-Act. Software filters are included to improve sharpness and contrast. 3D measurements can be taken directly on the radio.

Acquisition

Data acquisition

The workpiece previously positioned in the equipment rotates through 360°. During this rotation, a set of radio projections are acquired at different angles.

Reconstruction

Data processing

All the projections made during the acquisition step are reconstructed in a 3D volume. This will serve as the basis for the optional step: quantitative analysis.

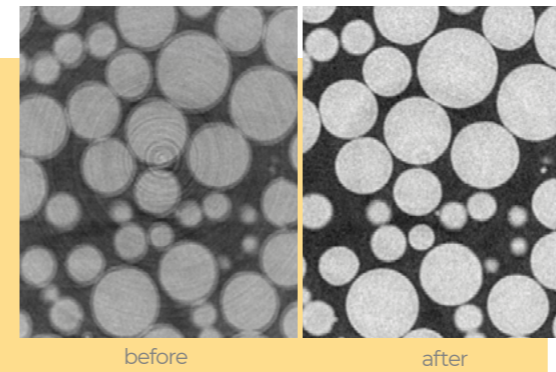

Advanced Artefact Corrections

X-Act software suite by RX Solutions includes multiple artefacts compensations plugins that enhance CT scans:

Geometry, focal spot movement, phase contrast, ring artefact, beam hardening, metal artefacts and more

Ease of use

thanks to X-Act guided acquisition & wizard modes

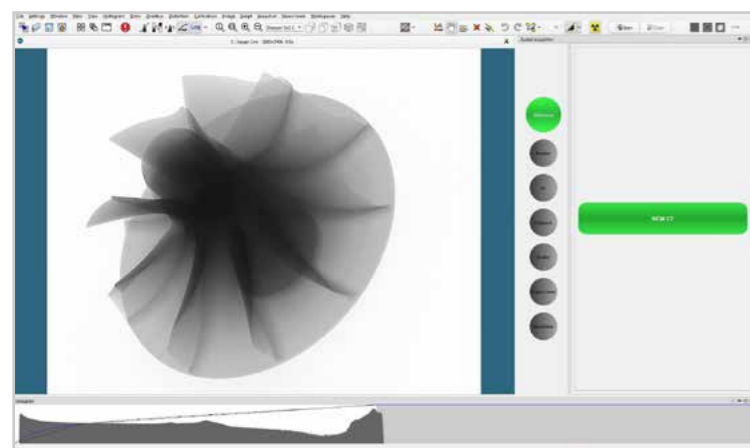

Guided acquisition mode is designed to configure the acquisition parameters step by step with the user and suggest the preferable settings values at each step.

Wizard mode is a fully automatic acquisition tool. The user acts as supervisor and the complete acquisition process is defined and executed by the system.

Regardless of your expertise, you will obtain results of highest quality.

Automation, Macro & Scripting

These functions allow the programming of automatic scans when carrying out inspections of large series of samples.

They can drastically increase the throughput of your CT system and the overall productivity. Unique scripting capabilities allow you to extend or custom fit the system to your needs.

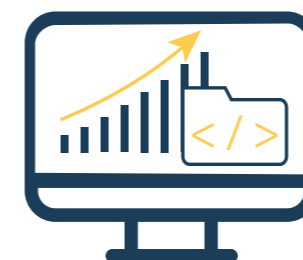

Continuous Improvement Strategy

Our team is continuously working to provide customers with the best X-Act experience by focusing on high-level image processing and tomographic reconstruction. X-Act is improved with innovations, especially developed to enhance capabilities, increase speed or release features the industry has never seen before.

Since the beginning, the flexible spirit behind X-Act has been kept, making this software a perfect CT tool for every application.

TECHNICAL SPECIFICATIONS

OUR PRODUCT PORTFOLIO FEATURES

	Max kV	Max power	Types	Max resolution ¹	EasyTom S	EasyTom	EasyTom XL	UltraTom
X-ray tubes	Micro 110	16 W	Sealed	2 µm	•			
	Micro 130	39 W	Sealed	5 µm	•	•	•	•
	Micro 150	75 W	Sealed	5 µm	•	•	•	•
	Micro 230	200 W	Open	2 µm / 4 µm		•	•	•
	Micro 300	300 W	Open	4 µm				•
	Nano 160	16 W	Open	0.4 µm		•	•	•
Dual tube configuration						•	•	•

¹ JIMA chart resolution

	Type	Pixel matrix	Pixel pitch	Sizes	EasyTom S	EasyTom	EasyTom XL	UltraTom
Detectors²	Flat Panel	1920x1536	127 µm	25 x 20 cm	•	•	•	•
	Flat Panel	2048x2560	124 µm	32 x 25 cm	•	•	•	•
	Flat Panel	3072x3072	139 µm	43 x 43 cm		•	•	•
	Camera	4008x2672	9 µm	36 x 24 mm	•	•	•	•

² other detectors available on request

Mechanic	High-grade optical honeycomb breadboard table that ensures stability for micro-CT scans		•	•		
	Granite-base that ensures temperature stability and good damping properties	•	•	•	•	•

	EasyTom S	EasyTom		EasyTom XL			UltraTom
		Micro	Nano	Micro	Nano	Ultra	
Mechanic							
N° of axes	4	9	9	9	9	9	9
Max SDD³	610 mm	910 mm	780 mm	1470 mm	780 mm	1100 mm	1640 mm
Scan volume	∅ 180 x 400 mm	∅ 320 x 530 mm	∅ 320 x 300 mm	∅ 600 x 720 mm	∅ 320 x 300 mm	∅ 520 x 650 mm	∅ 520 x 650 mm
Max sample weight	5 kg	30 kg	20 kg	100 kg	20 kg	80 kg	100 kg
General							
Weight	1020 kg	3300 kg	2500 kg	7000 kg	5000 kg	7400 kg	7000 kg
External dim	1430(W)x900(D)x1870(H) mm	2200 (W) x 1114 (D) x 2000 (H) mm		2860 (W) x 1860 (D) x 2400 (H) mm			3230(W)x1420(D)x2520(H) mm
Radiation safety	High grade X-ray shielded cabinet (< 0.5 µSv / h at any place of the instrument surface) for integral protection						Placed in a shielded operation room
Software	All systems are controlled by RX Solutions X-Act software						

³ Source to Detector Distance

// EasyTom S

High Resolution Industrial CT System for Small / Medium Size Parts

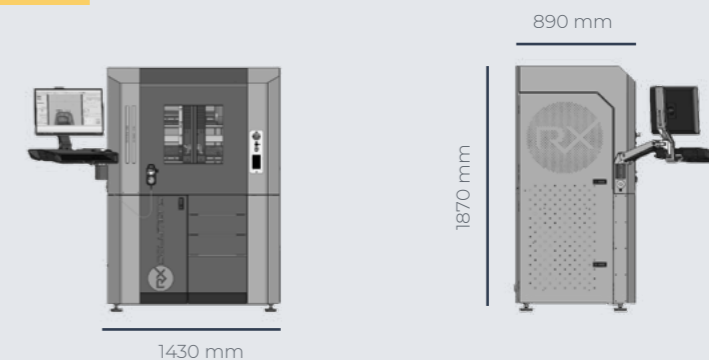

// EasyTom

High Resolution Micro & Nano CT System for Medium Size Parts

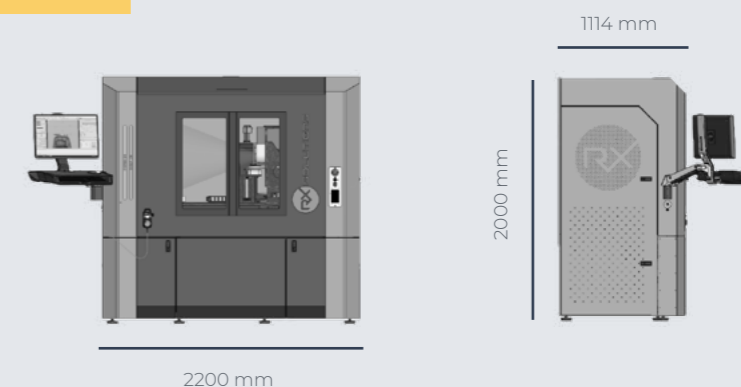

// EasyTom XL

High Resolution Micro & Nano CT System for Large Size Parts

Very Large step-in cabinet

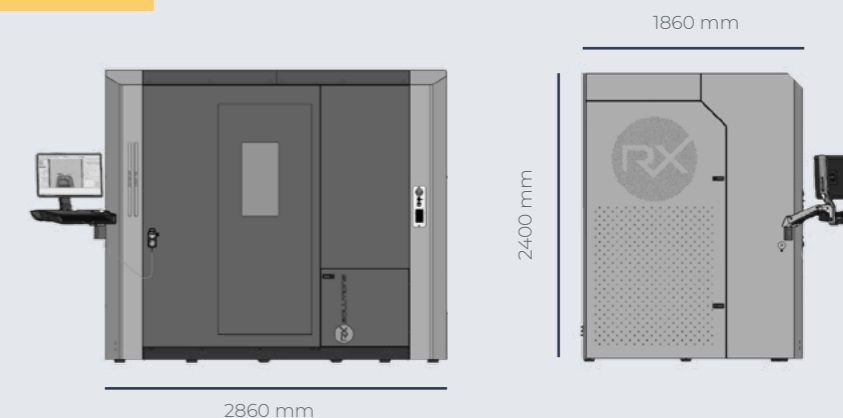

// UltraTom

Modular Design for a Highly Versatile X-ray Micro & Nano CT System

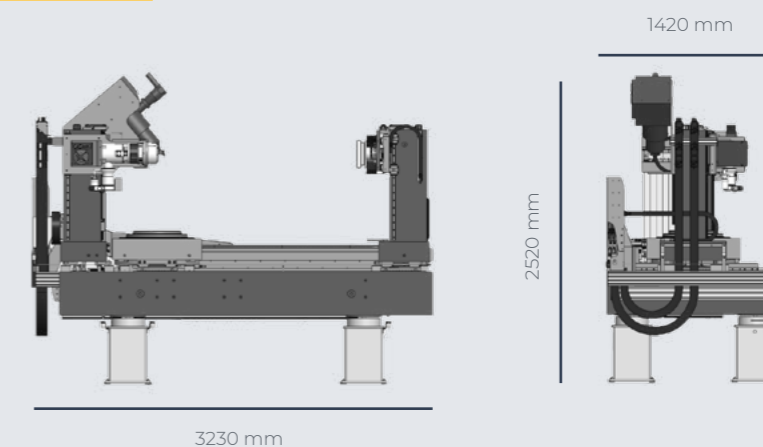



sales@rx-solutions.com
www.rx-solutions.com

24 Bis, rue Uranus, ZAC Altaïs
F-74650 Chavanod FRANCE
Tél. +33 (0)4 50 67 39 52



© 2021 RX Solutions. All rights reserved.